

SA OV - Storage tank for outdoor use



Storage of fluids in general (other than water) in compliance with the regulations. Designed to withstand only to the hydrostatic pressure of their content increased by 1-2 mt.

Hydraulic test seals.

TECHNICAL CHARACTERISTICS

Tank	Material:	S 235 Jr
	Internal protective processing:	Rough
	External Protective processing:	Coating with industrial glaze with chlorinated rubber / fiberglass
	Operation (P max. / T max.):	Atmospheric pressure / 25°C
General characteristics	Warranty:	2 years for construction defects

FITTINGS

- Containment basin
- Roof
- Terminator flame arrestor approved 1 1/2" (p. 217)
- Metric rod (p. 217)

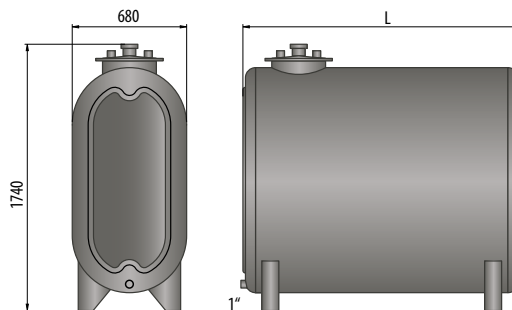
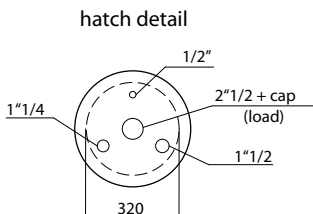

SA OV	
Capacity (Lt)	Dimensions (mm) L
1100	1150
1600	1650
2000	2150

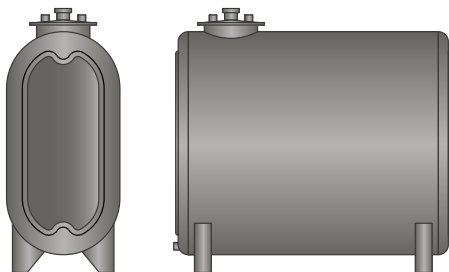

SA OV - Oval tank				
Capacity (Lt)	Painted		Fiberglass	
	Code	€	Code	€
1100	SA 01100 O	-	SA 01100 OVT	-
1600	SA 01600 O	-	SA 01600 OVT	-
2000	SA 02000 O	-	SA 02000 OVT	-

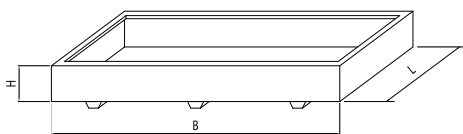

* With provision for roof

Containment basin - roof SA OV							
Lt	Containment basin 50%					Roof	
	L	B	H	Code	€	Code	€
1100	900	1500	450	BC 1100 OV	-	TT 1100 OV	-
1600	900	2000	450	BC 1600 OV	-	TT 1600 OV	-
2000	900	2500	450	BC 2000 OV	-	TT 2000 OV	-