

AISI 316L Stainless steel calorifier for heat pumps

WP1X - With one coil for heat pumps

WP2X - With two coils for heat pumps and solar systems



Calorifiers made of AISI 316L Stainless steel, designed for the production and storage of domestic hot water (DHW). They are equipped with one or two internal fixed coils that can be fed by a heat pump and by a solar system and/or a boiler. The special heat exchanger with enhanced exchanging capacity, allows a more efficient spread of the power delivered by the heat pump

on the coldest part of the cylinder, thus reducing the number of on-off cycles of the compressor and increasing its lifespan. The wide range of capacities (from 200 to 2000 litres) allows their installation in several systems, from domestic use to commercial applications. Cylinders are also prepared to host a backup immersion heater (not supplied).

HEAT SOURCE



APPLICATION



TECHNICAL FEATURES	DHW cylinder	Material	AISI 316L Stainless steel (1.4404)
		Internal protective treatment	Pickling and passivation
	External protective treatment	Pickling and passivation	
	Rating (P max. / T max.)	6 bar / 95°C	
	Cathodic protection	Magnesium anode	
	Heat exchanger	Material	AISI 316L Stainless steel (1.4404)
		Internal protective treatment	Pickling and passivation
	External protective treatment	Pickling and passivation	
	Type	Fixed coil for 200 litres capacity Double spiral fixed coil for capacities above 300 litres	
	Rating (P max. / T max.)	10 bar / 95°C	
	Capacity	200 - 2000 L	
	Warranty	5 years	
	Insulation	- Rigid polyurethane foam + PVC: Fire retardant class B3 (DIN 4102) - Soft insulation with polyester + PVC: Fire retardant class B2 (DIN 4102)	
	General features	In compliance with	- Pressure Equipment Directive (PED) 2014/68/UE Art. 4 Para 3 - Italian MOH specifications (products suitable to contain potable water) - Energy related Products (Erp) Directive 2009/125/CE

ACCESSORIES (page 218)

- Impressed current electronic anode
- Electronic control unit
- Thermostat
- Thermometer
- 1 1/2 electric immersion heater

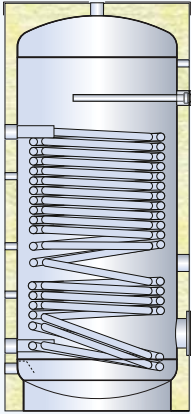

WP1X - Hard insulation with rigid polyurethane foam and PVC jacket

CODE	INSULATION THICK. (mm)	ErP CLASS	HEAT LOSS S (W)	REAL CAPACITY (L)	HEAT EXCHANGER (m ²) / (L) *
WP1X 00200 R	50	B	56,7	189,8	1,90 / 18,6
WP1X 00300 R	50	B	69,2	290,3	3,50 / 34,3
WP1X 00400 R	50	B	73,0	414,9	4,50 / 44,1
WP1X 00500 R	50	B	81,6	500,3	5,70 / 55,9
WP1X 00600 R	50	B	90,2	585,7	5,70 / 55,9
WP1X 00800 R	100	C	106,6	749,8	6,00 / 58,8
WP1X 01000 R	100	C	110,5	931,5	6,00 / 58,8
WP1X 01500 R	100	C	133	1474,3	7,50 / 73,5
WP1X 02000 R	100	C	143,3	1951,9	10,40 / 101,9

WP1X - Soft insulation with polyester and PVC jacket

CODE	INSULATION THICK. (mm)	ErP CLASS	HEAT LOSS S (W)	REAL CAPACITY (L)	HEAT EXCHANGER (m ²) / (L) *
WP1X 00800 F	130	C	126,6	749,8	6,00 / 58,8
WP1X 01000 F	130	C	138,4	931,5	6,00 / 58,8
WP1X 01500 F	130	C	168,3	1474,3	7,50 / 73,5
WP1X 02000 F	130	C	181,8	1951,9	10,40 / 101,9

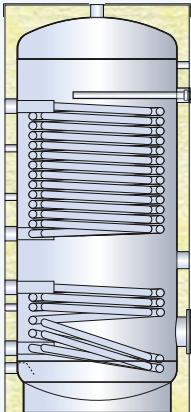

WP2X - Hard insulation with rigid polyurethane foam and PVC jacket

CODE	INSULATION THICK. (mm)	ErP CLASS	HEAT LOSS S (W)	REAL CAPACITY (L)	LOWER HEAT EXCHANGER (m ²) / (L) *	UPPER HEAT EXCHANGER (m ²) / (L) *
WP2X 00300 R	50	B	69,2	290,3	1,00 / 9,8	2,40 / 23,5
WP2X 00400 R	50	B	73,0	414,9	1,20 / 11,8	3,00 / 29,4
WP2X 00500 R	50	B	81,6	500,3	1,50 / 14,7	4,20 / 41,2
WP2X 00600 R	50	B	90,2	585,7	2,00 / 19,6	5,00 / 49,0
WP2X 00800 R	100	C	106,6	749,8	2,00 / 19,6	5,20 / 51,0
WP2X 01000 R	100	C	110,5	931,5	3,30 / 32,3	6,00 / 58,8
WP2X 01500 R	100	C	133	1474,3	3,60 / 35,3	7,50 / 73,5
WP2X 02000 R	100	C	143,3	1951,9	5,50 / 53,9	8,50 / 83,3

WP2X - Soft insulation with polyester and PVC jacket

CODE	INSULATION THICK. (mm)	ErP CLASS	HEAT LOSS S (W)	REAL CAPACITY (L)	LOWER HEAT EXCHANGER (m ²) / (L) *	UPPER HEAT EXCHANGER (m ²) / (L) *
WP2X 00800 F	130	C	126,6	749,8	2,00 / 19,6	5,20 / 51,0
WP2X 01000 F	130	C	138,4	931,5	3,30 / 32,3	6,00 / 58,8
WP2X 01500 F	130	C	168,3	1474,3	3,60 / 35,3	7,50 / 73,5
WP2X 02000 F	130	C	181,8	1951,9	5,50 / 53,9	8,50 / 83,3

* Volume occupied by the heat exchanger and its support structure

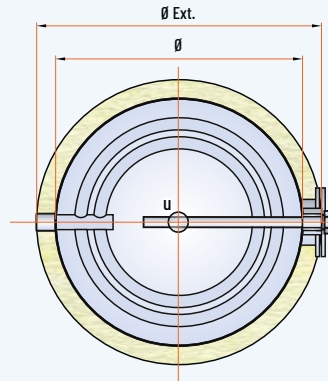
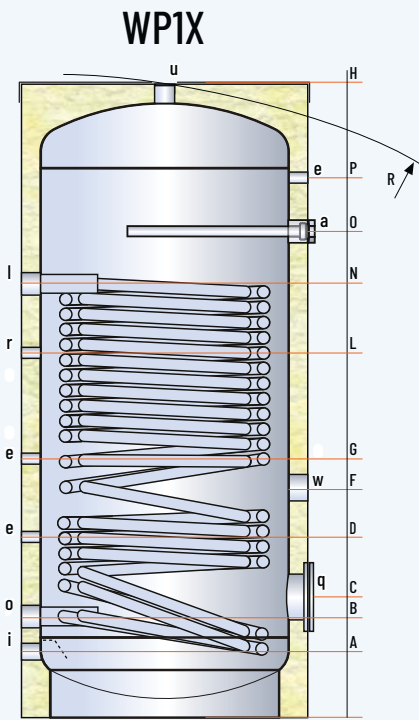

LEGEND

- a . Magnesium anode
- e . Thermometer - Sensor
- i . Domestic cold water inlet
- l . Heat pump flow
- o . Heat pump return
- q . DHW inspection hatch
- r . Recirculation
- u . Domestic hot water outlet
- w . Opening for immersion heater

Detail of the total drain pipe only for the 2000 litres model

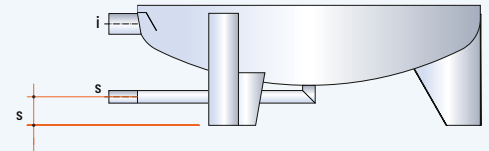

MODEL	DIMENSIONS (mm)		Ø EXT **	R *	HEAT EXCHANGER	WEIGHT
	Ø	H	(Hard/Soft ins.)		(m ²)	(kg)
WP1X 00200 R	450	1305	550	1430	1,90 ***	64
WP1X 00300 R	500	1595	600	1720	3,50	91
WP1X 00400 R	650	1395	750	1600	4,50	110
WP1X 00500 R	650	1645	750	1820	5,70	131
WP1X 00600 R	650	1895	750	2050	5,70	142
WP1X 00800_	790	1750	990/1050	1745	6,00	168
WP1X 01000_	790	2110	990/1050	2095	6,00	188
WP1X 01500_	1000	2115	1200/1260	2145	7,50	271
WP1X 02000_	1100	2465	1300/1360	2465	10,40	362

* For capacities from 200 to 600 litres, the tilt height refers to the insulated cylinder

** The insulation is removable except for models from 200 to 600 litres

*** Fixed single spiral coil

MODEL	HEIGHTS (mm)											CONNECTIONS (GAS)							
	A	B	C	D	F	G	L	N	O	P	S	a	lo	e	r	iu	s	w	q
WP1X 00200 R	95	187	262	342	623	623	743	1077	953	1087	-	1"¼	1"	½"	½"	1"	-	1"½	120/180
WP1X 00300 R	120	210	300	320	495	780	925	1110	1160	1365	-	1"¼	1"¼	½"	½"	1"	-	1"½	120/180
WP1X 00400 R	145	240	310	340	525	680	870	1005	1030	1140	-	1"¼	1"¼	½"	½"	1"	-	1"½	120/180
WP1X 00500 R	145	240	310	350	570	810	1020	1250	1280	1390	-	1"¼	1"¼	½"	½"	1"	-	1"½	120/180
WP1X 00600 R	145	240	310	390	605	930	1070	1250	1510	1640	-	1"¼	1"¼	½"	½"	1"	-	1"½	120/180
WP1X 00800_	170	275	345	405	620	840	1000	1170	1310	1425	-	1"¼	1"¼	½"	1"	1"½	-	1"½	120/180
WP1X 01000_	170	275	345	475	750	1000	1120	1275	1615	1770	-	1"¼	1"¼	½"	1"	1"½	-	1"½	120/180
WP1X 01500_	230	345	475	535	805	1030	1165	1325	1600	1740	-	1"¼	1"¼	½"	1"	2"	-	1"½	220/290
WP1X 02000_	325	455	585	655	1030	1240	1385	1530	1885	2035	100	1"¼	1"¼	½"	1"	2"	1"	1"½	220/290

Disclaimer: this layout is purely indicative. It does not replace consultant's design

LEGEND

- 1 . Domestic water expansion vessel
- 2 . Domestic water drain
- 3 . Domestic water safety valve (6 bar)
- 4 . Strainer
- 5 . Pressure reducing valve
- 6 . DWH Recirculation pump
- 7 . DWH 3-way valve

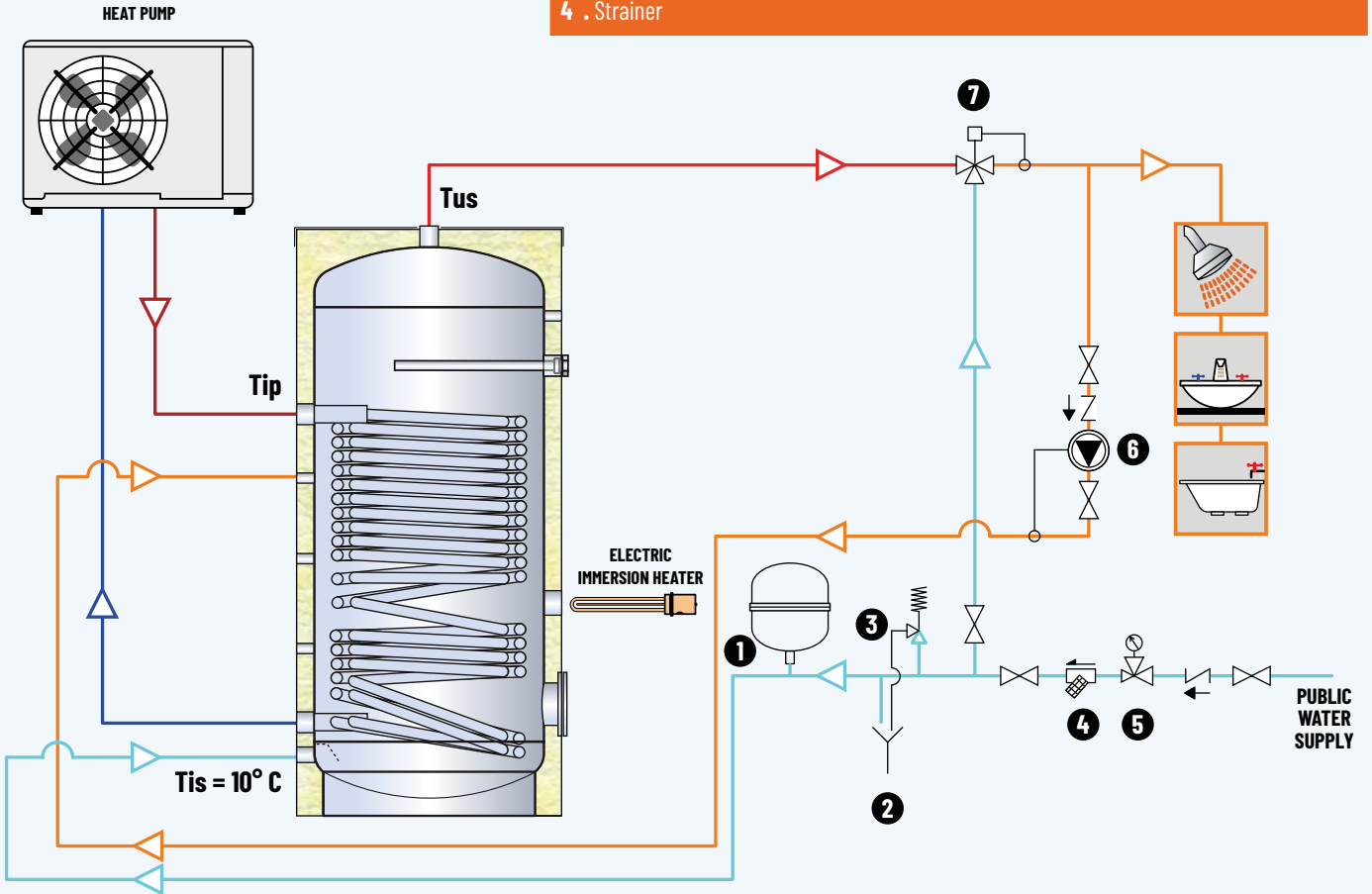

MODEL		WPIX 00200R				WPIX 00300R				WPIX 00400R			
DHW FROM 10 TO 45 °C	HEAT EXCHANGER (m ²) [L] ¹	1,9 [13,5]				3,5 [24,9]				4,5 [32,0]			
	PRIMARY FLOW (m ³ /h)	2				2				3			
	PRIMARY TEMP. (°C)	50	60	70	80	50	60	70	80	50	60	70	80
	LITRES 10' (L/10') ²	249	296	413	452	390	462	642	701	546	643	896	977
	LITRES FIRST HOUR ²	595	872	1193	1425	962	1391	1880	2235	1305	1887	2562	3044
	CONTINUOUS DRAW (L) ³	437	729	984	1229	722	1173	1565	1938	959	1571	2104	2612
DHW FROM 10 TO 60 °C	POWER (kW)	18	30	40	50	29	48	64	79	39	64	86	106
	PREHEATING ³ (min)	29	17	12	10	29	17	12	10	31	18	13	10
	LITRES 10' (L/10') ²	-	-	260	291	-	-	406	455	-	-	568	634
	LITRES FIRST HOUR ²	-	-	657	846	-	-	1057	1349	-	-	1434	1831
	CONTINUOUS DRAW (L) ³	-	-	501	701	-	-	822	1129	-	-	1095	1512
	POWER (kW)	-	-	29	41	-	-	48	66	-	-	63,7	87,9
NL ⁴	4				11				20				

MODEL		WPIX 00500R				WPIX 00600R				WPIX 00800_			
DHW FROM 10 TO 45 °C	HEAT EXCHANGER (m ²) [L] ¹	5,7 [40,5]				5,7 [40,5]				6,0 [42,6]			
	PRIMARY FLOW (m ³ /h)	3				3				3			
	PRIMARY TEMP. (°C)	50	60	70	80	50	60	70	80	50	60	70	80
	LITRES 10' (L/10') ²	658	771	1072	1165	739	852	1188	1281	902	1018	1424	1520
	LITRES FIRST HOUR ²	1571	2247	3037	3595	1652	2329	3153	3711	1851	2548	3458	4032
	CONTINUOUS DRAW (L) ³	1153	1865	2482	3070	1153	1866	2483	3070	1198	1933	2569	3173
DHW FROM 10 TO 60 °C	POWER (kW)	47	76	101	125	47	76	101	125	49	79	105	129
	PREHEATING ³ (min)	32	19	14	11	37	22	16	13	47	27	20	16
	LITRES 10' (L/10') ²	-	-	683	760	-	-	764	841	-	-	928	1007
	LITRES FIRST HOUR ²	-	-	1721	2182	-	-	1802	2263	-	-	2005	2480
	CONTINUOUS DRAW (L) ³	-	-	1311	1796	-	-	1311	1796	-	-	1361	1861
	POWER (kW)	-	-	76	104	-	-	76	104	-	-	79,1	108,2
NL ⁴	30				34				44				

MODEL		WPIX 01000_				WPIX 01500_				WPIX 02000_			
DHW FROM 10 TO 45 °C	HEAT EXCHANGER (m ²) [L] ¹	6,0 [42,6]				7,5 [53,3]				10,4 [73,8]			
	PRIMARY FLOW (m ³ /h)	3				4				5			
	PRIMARY TEMP. (°C)	50	60	70	80	50	60	70	80	50	60	70	80
	LITRES 10' (L/10') ²	1075	1191	1671	1767	1642	1791	2520	2643	2180	2378	3344	3507
	LITRES FIRST HOUR ²	2023	2721	3704	4278	2846	3741	5118	5856	3807	4997	6821	7799
	CONTINUOUS DRAW (L) ³	1198	1933	2568	3173	1522	2464	3281	4058	2056	3308	4391	5421
DHW FROM 10 TO 60 °C	POWER (kW)	49	79	105	129	62	100	134	165	84	135	179	221
	PREHEATING ³ (min)	58	34	24	19	71	41	30	24	71	41	30	24
	LITRES 10' (L/10') ²	-	-	1100	1180	-	-	1675	1776	-	-	2224	2359
	LITRES FIRST HOUR ²	-	-	2178	2653	-	-	3045	3655	-	-	4071	4882
	CONTINUOUS DRAW (L) ³	-	-	1361	1861	-	-	1731	2373	-	-	2333	3187
	POWER (kW)	-	-	79	108	-	-	101	138	-	-	135,7	185,3
NL ⁴	53				86				101				

(1) Volume of fluid contained in the heat exchanger

(2) Obtainable with pre-heated cylinder (at 45 °C with primary side set at 50 or 60 °C and pre-heated at 60 °C in the other cases) and a running heat source

(3) With a proper power heat source generator

(4) Primary side 80 °C - Secondary side 10-45 °C

WP1X - Heat exchanger powers with secondary side at 10/45 °C

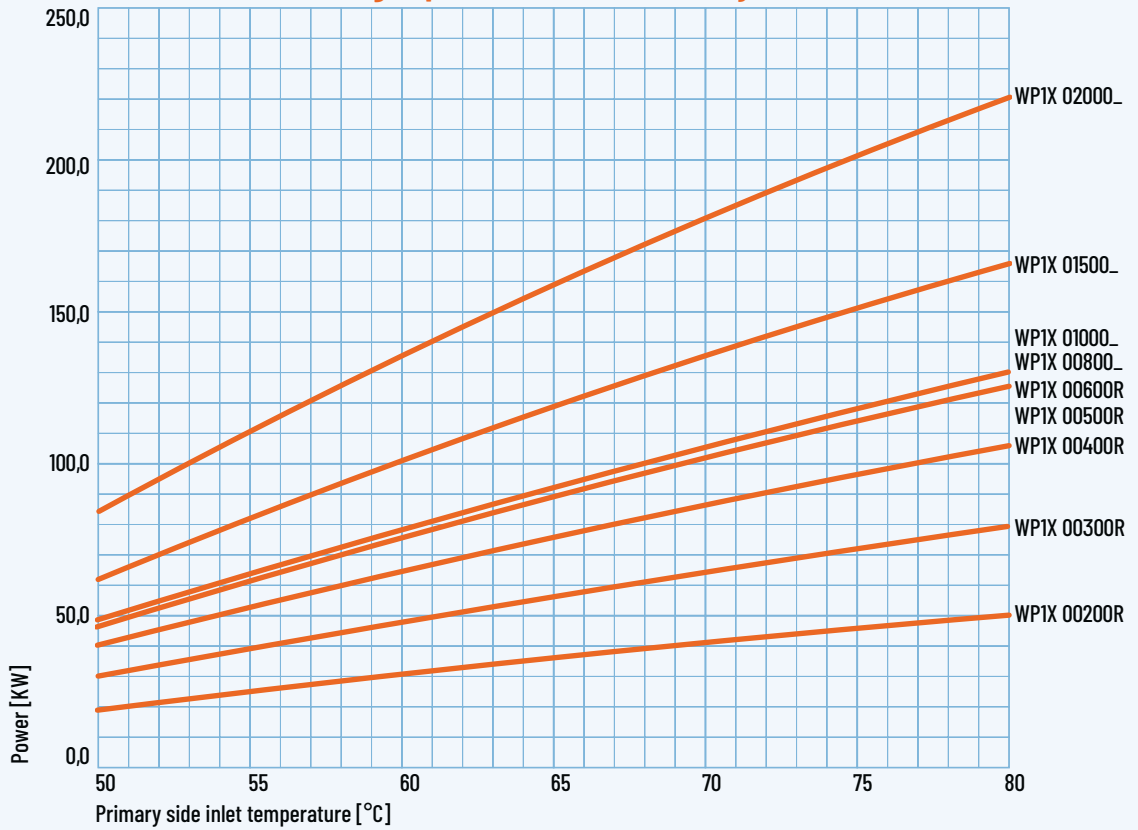

WP1X - Heat exchanger pressure drops

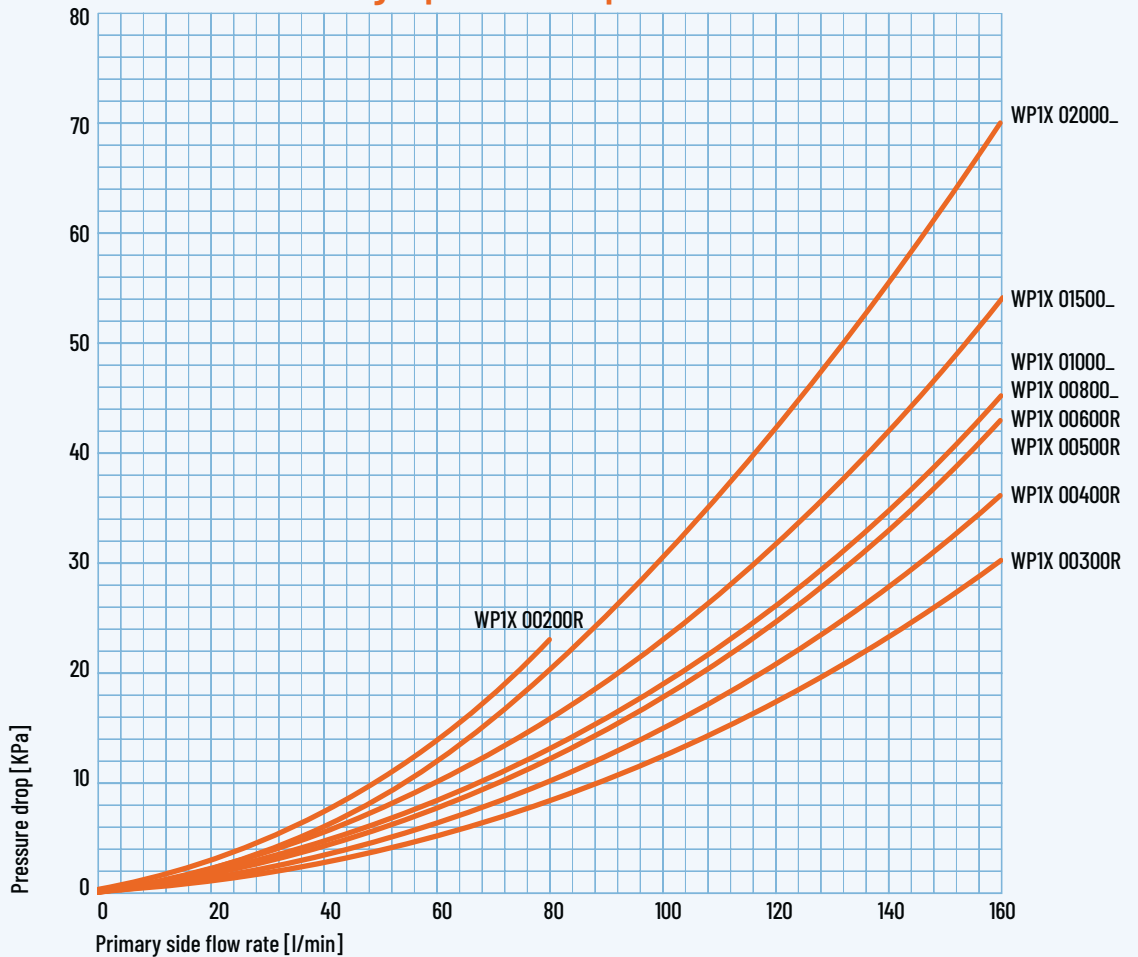

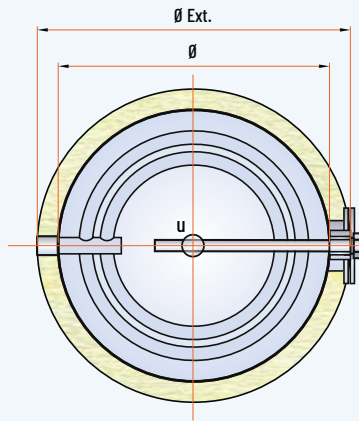
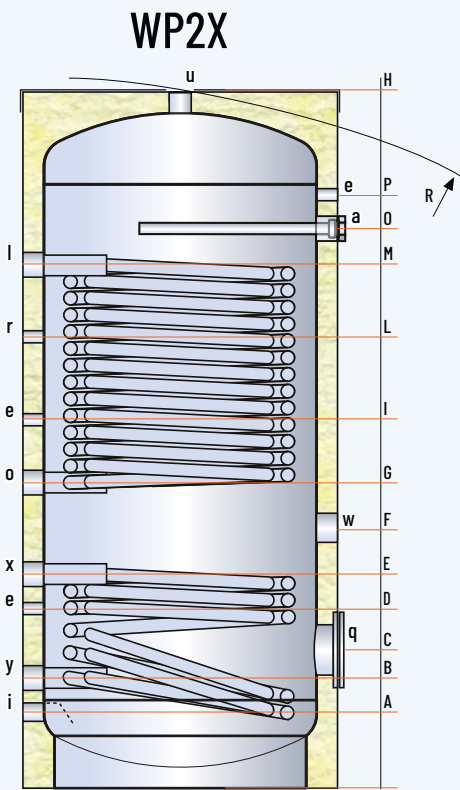

LEGEND

- a . Magnesium anode
- e . Thermometer - Sensor
- i . Domestic cold water inlet
- l . Heat pump flow
- o . Heat pump return
- q . DHW inspection hatch
- r . Recirculation
- u . Domestic hot water outlet
- w . Opening for immersion heater
- x . Solar system flow
- y . Solar system return

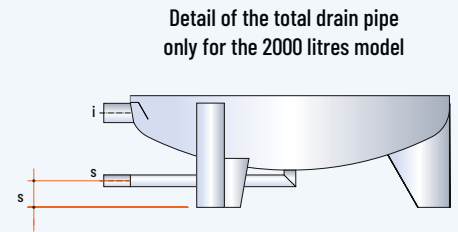

MODEL	DIMENSIONS (mm)		Ø EXT **	R *	LOWER HEAT EXCHANGER (m ²)	UPPER HEAT EXCHANGER (m ²)	WEIGHT (kg)
	Ø	H	(Hard/Soft ins.)				
WP2X 00300 R	500	1595	600	1720	1,00	2,40	90
WP2X 00400 R	650	1395	750	1600	1,20	3,00	107
WP2X 00500 R	650	1645	750	1820	1,50	4,20	131
WP2X 00600 R	650	1895	750	2050	2,00	5,00	154
WP2X 00800_	790	1750	990/1050	1745	2,00	5,20	179
WP2X 01000_	790	2110	990/1050	2095	3,30	6,00	219
WP2X 01500_	1000	2115	1200/1260	2145	3,60	7,50	305
WP2X 02000_	1100	2465	1300/1360	2465	5,50	8,50	396

* For capacities from 300 to 600 litres, the tilt height refers to the insulated cylinder
 ** The insulation is removable except for models from 300 to 600 litres

MODEL	HEIGHTS (mm)													CONNECTIONS (GAS)											
	A	B	C	D	E	F	G	I	L	M	O	P	S	a	l	x	y	e	r	i	u	s	w	q	
WP2X 00300 R	120	210	300	320	430	495	560	745	925	1110	1160	1365	-	1"¼	½"	½"	1"	-	1"½	120/180					
WP2X 00400 R	145	240	310	340	440	525	565	720	870	1005	1030	1140	-	1"¼	½"	½"	1"	-	1"½	120/180					
WP2X 00500 R	145	240	310	350	460	570	610	820	1020	1250	1280	1390	-	1"¼	½"	½"	1"	-	1"½	120/180					
WP2X 00600 R	145	240	310	390	540	605	670	870	1070	1470	1510	1640	-	1"¼	½"	½"	1"	-	1"½	120/180					
WP2X 00800_	170	275	345	405	535	620	665	835	1000	1270	1310	1425	-	1"¼	½"	1"	1"½	-	1"½	120/180					
WP2X 01000_	170	275	345	475	675	750	825	975	1120	1575	1615	1770	-	1"¼	½"	1"	1"½	-	1"½	120/180					
WP2X 01500_	230	345	475	535	730	805	880	1025	1165	1560	1600	1740	-	1"¼	½"	1"	2"	-	1"½	220/290					
WP2X 02000_	325	455	585	655	955	1030	1105	1245	1385	1805	1885	2035	100	1"¼	½"	1"	2"	1"	1"½	220/290					

Disclaimer: this layout is purely indicative. It does not replace consultant's design

LEGEND

- | | |
|---|--------------------------------------|
| 1 . Domestic water expansion vessel | 7 . DHW 3-way valve |
| 2 . Domestic water drain | 8 . Vent with valve |
| 3 . Domestic water safety valve (6 bar) | 9 . Solar system control unit |
| 4 . Strainer | 10 . Solar system safety kit (6 bar) |
| 5 . Pressure reducing valve | 11 . Solar system expansion vessel |
| 6 . DWH Recirculation pump | |

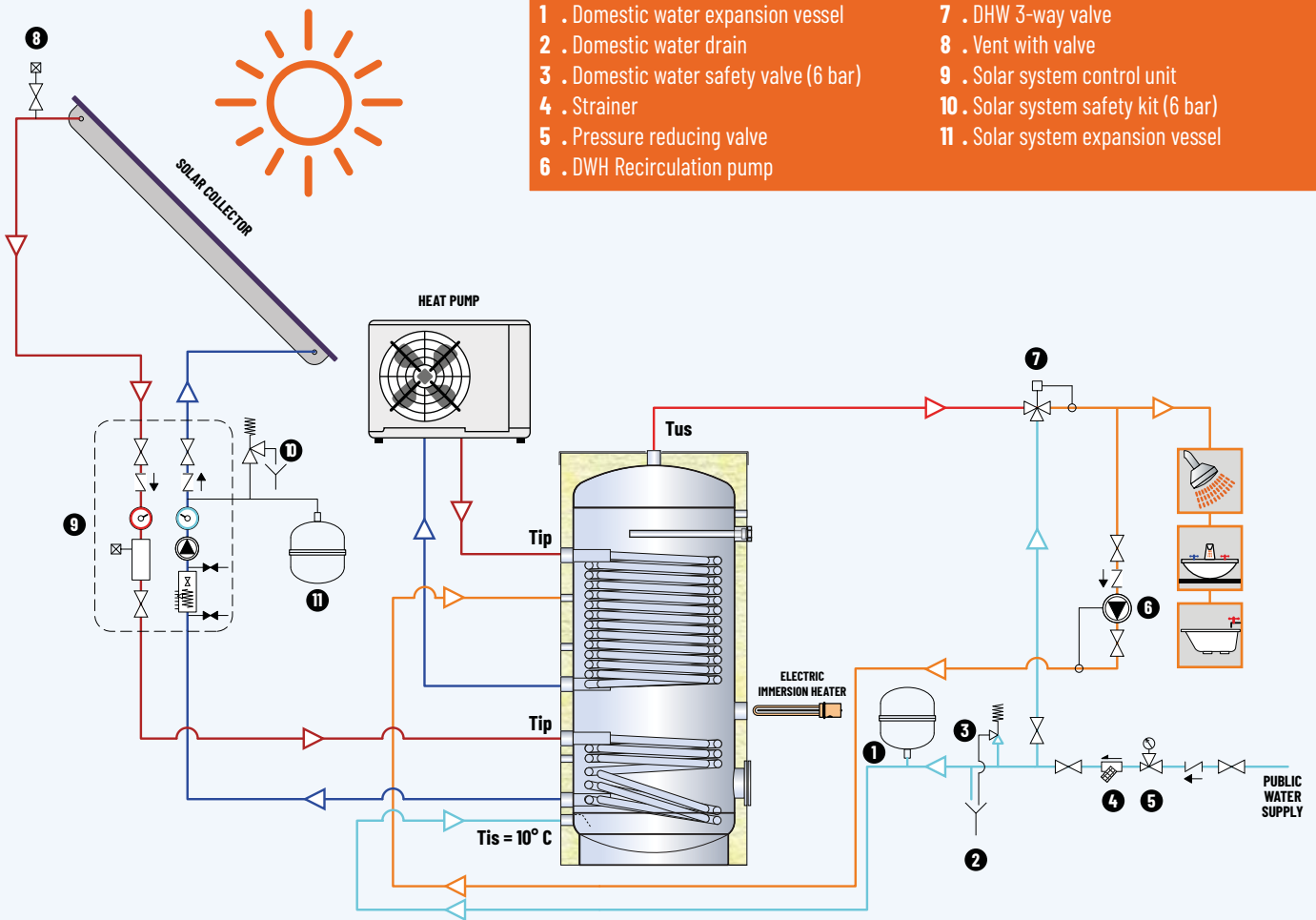

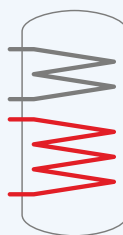

Data related to the lower heat exchanger

MODEL		WP2X 00300R				WP2X 00400R				WP2X 00500R			
	HEAT EXCHANGER (m ²) [L] ¹	1,0 [7,1]				1,2 [8,5]				1,5 [10,6]			
	PRIMARY FLOW (m ³ /h)	2				3				3			
	PRIMARY TEMP. (°C)	50	60	70	80	50	60	70	80	50	60	70	80
DHW FROM 10 TO 45 °C	LITRES 10' (L/10') ²	315	342	484	507	441	475	673	701	534	574	813	848
	LITRES FIRST HOUR ²	509	671	932	1069	678	877	1222	1391	825	1068	1486	1692
	CONTINUOUS DRAW (L) ³	245	416	566	711	299	508	693	871	368	623	849	1066
	POWER (kW)	10	17	23	29	12	21	28	35	15	25	35	43
	PREHEATING ³ (min)	75	44	32	25	87	50	37	29	86	50	36	29
DHW FROM 10 TO 60 °C	LITRES 10' (L/10') ²	-	-	321	339	-	-	449	471	-	-	542	570
	LITRES FIRST HOUR ²	-	-	545	655	-	-	722	858	-	-	878	1045
	CONTINUOUS DRAW (L) ³	-	-	283	400	-	-	345	488	-	-	424	599
	POWER (kW)	-	-	16	23	-	-	20	28	-	-	24,7	34,9
	PREHEATING ³ (min)	-	-	65	45	-	-	75	52	-	-	74	52
NL ⁴	4				6				8				
MODEL		WP2X 00600R				WP2X 00800_				WP2X 01000_			
	HEAT EXCHANGER (m ²) [L] ¹	2,0 [14,2]				2,0 [14,2]				3,3 [23,4]			
	PRIMARY FLOW (m ³ /h)	3				3				3			
	PRIMARY TEMP. (°C)	50	60	70	80	50	60	70	80	50	60	70	80
DHW FROM 10 TO 45 °C	LITRES 10' (L/10') ²	632	684	968	1012	788	840	1191	1235	1003	1080	1527	1592
	LITRES FIRST HOUR ²	1011	1322	1835	2098	1167	1478	2058	2321	1591	2056	2842	3232
	CONTINUOUS DRAW (L) ³	479	806	1095	1372	479	806	1095	1372	743	1233	1661	2071
	POWER (kW)	19	33	45	56	19	33	45	56	30	50	68	84
	PREHEATING ³ (min)	79	46	33	27	101	59	43	34	85	49	36	29
DHW FROM 10 TO 60 °C	LITRES 10' (L/10') ²	-	-	644	679	-	-	800	835	-	-	1020	1073
	LITRES FIRST HOUR ²	-	-	1080	1293	-	-	1236	1449	-	-	1694	2011
	CONTINUOUS DRAW (L) ³	-	-	551	775	-	-	551	775	-	-	851	1186
	POWER (kW)	-	-	32	45,1	-	-	32	45	-	-	49	69
	PREHEATING ³ (min)	-	-	68	48	-	-	87	61	-	-	73	51
NL ⁴	13				16				29				
MODEL		WP2X 01500_				WP2X 02000_							
	HEAT EXCHANGER (m ²) [L] ¹	3,6 [25,5]				5,5 [39,0]							
	PRIMARY FLOW (m ³ /h)	4				5							
	PRIMARY TEMP. (°C)	50	60	70	80	50	60	70	80				
DHW FROM 10 TO 45 °C	LITRES 10' (L/10') ²	1533	1621	2299	2373	2050	2180	3087	3196				
	LITRES FIRST HOUR ²	2192	2723	3790	4236	3030	3806	5280	5929				
	CONTINUOUS DRAW (L) ³	833	1392	1883	2353	1238	2055	2769	3452				
	POWER (kW)	34	57	77	96	50	84	113	141				
	PREHEATING ³ (min)	117	68	50	39	107	62	45	36				
DHW FROM 10 TO 60 °C	LITRES 10' (L/10') ²	-	-	1552	1613	-	-	2079	2167				
	LITRES FIRST HOUR ²	-	-	2310	2673	-	-	3202	3732				
	CONTINUOUS DRAW (L) ³	-	-	957	1339	-	-	1419	1976				
	POWER (kW)	-	-	55,6	77,9	-	-	82,5	114,9				
	PREHEATING ³ (min)	-	-	101	71	-	-	92	65				
NL ⁴	43				51								

(1) Volume of fluid contained in the heat exchanger

(2) Obtainable with pre-heated cylinder (at 45 °C with primary side set at 50 or 60 °C and pre-heated at 60 °C in the other cases) and a running heat source

(3) With a proper power heat source generator

(4) Primary side 80 °C - Secondary side 10-45 °C

WP2X - Lower heat exchanger powers with secondary side at 10/45 °C

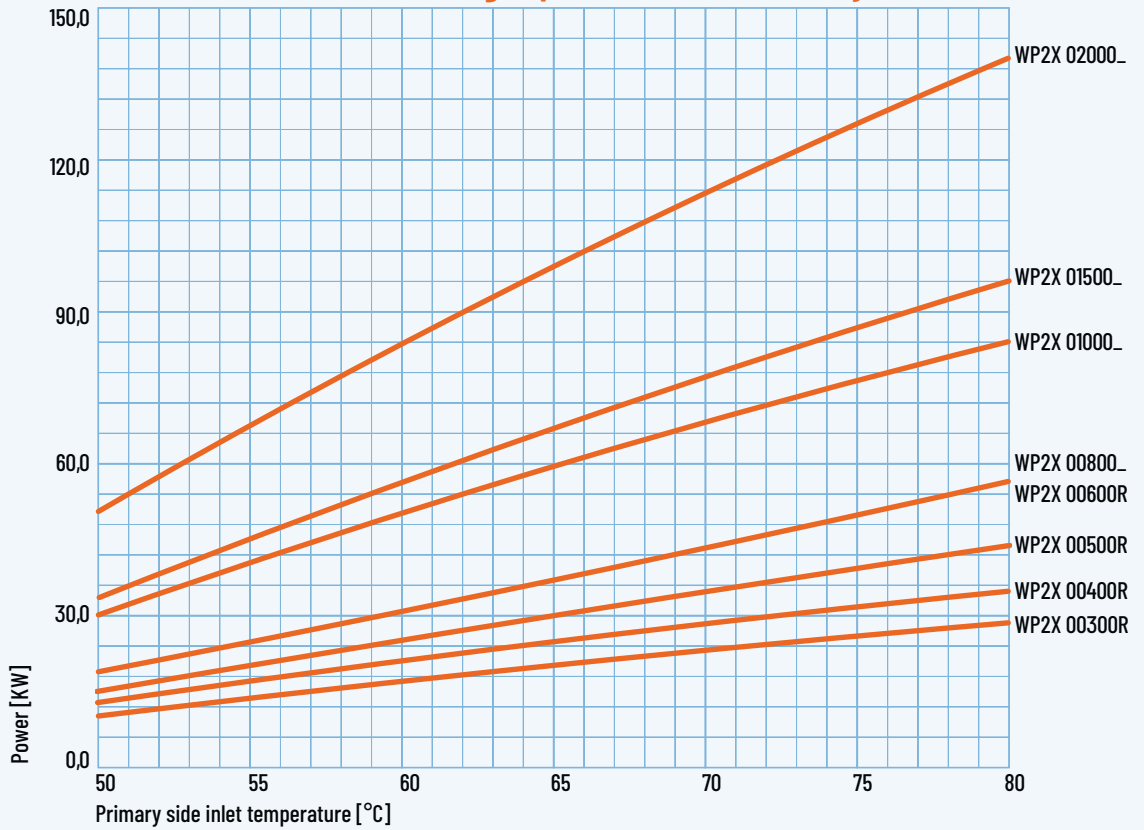

WP2X - Lower heat exchanger pressure drops

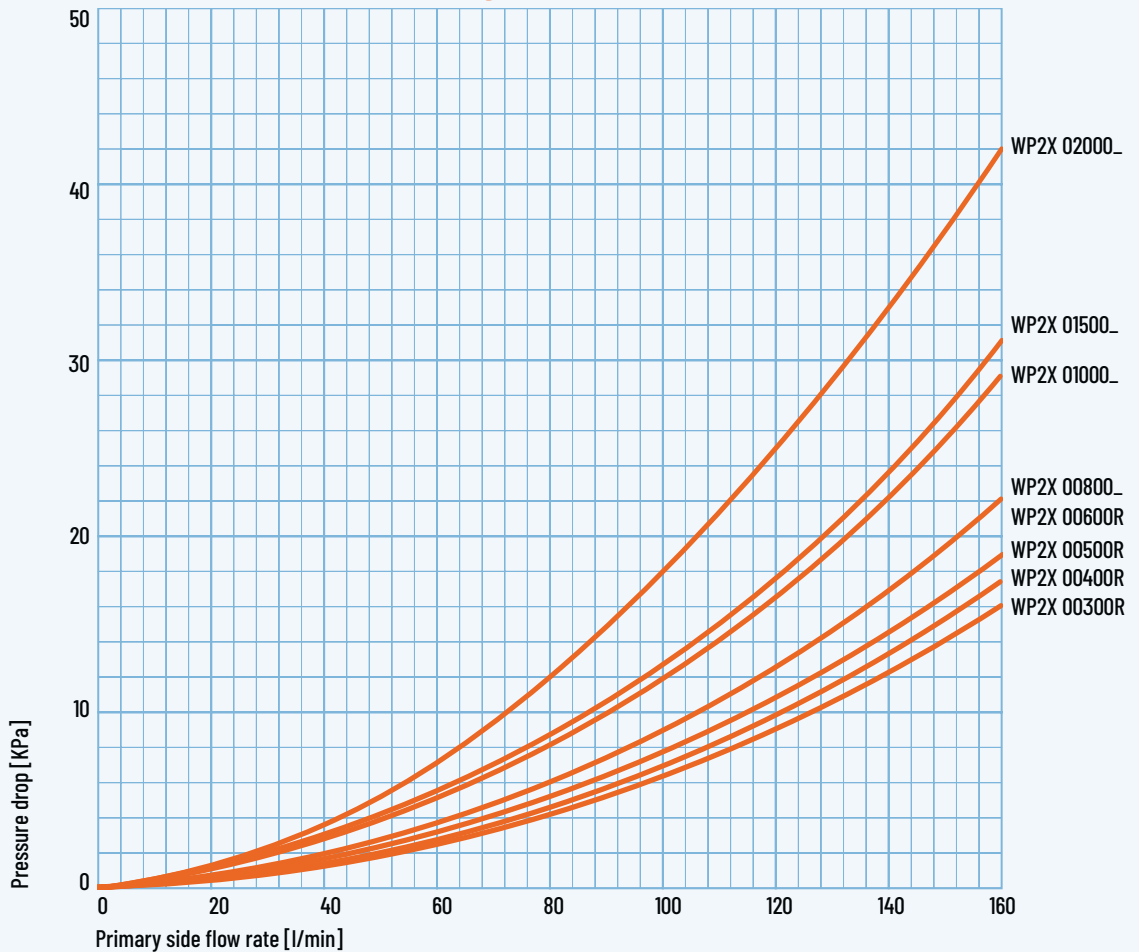



Data related to the upper heat exchanger

The performance values in the chart refer to the partial volume of water affected by the heat exchanger

MODEL		WP2X 00300R				WP2X 00400R				WP2X 00500R			
	HEAT EXCHANGER (m ²) [L] ¹	2,4 [17,0]				3,0 [21,3]				4,2 [29,8]			
	PRIMARY FLOW (m ³ /h)	2				3				3			
	PRIMARY TEMP. (°C)	50	60	70	80	50	60	70	80	50	60	70	80
DHW FROM 10 TO 45 °C	LITRES 10' (L/10') ²	265	320	445	492	345	417	582	643	445	538	747	824
	LITRES FIRST HOUR ²	687	1018	1385	1661	888	1320	1801	2164	1164	1718	2330	2792
	CONTINUOUS DRAW (L) ³	533	881	1186	1477	685	1140	1540	1922	907	1491	2000	2485
	POWER (kW)	22	36	48	60	28	46	63	78	37	61	81	101
	PREHEATING ³ (min)	24	14	10	8	24	14	10	8	24	14	10	8
DHW FROM 10 TO 60 °C	LITRES 10' (L/10') ²	-	-	277	315	-	-	361	411	-	-	466	529
	LITRES FIRST HOUR ²	-	-	760	986	-	-	983	1279	-	-	1286	1665
	CONTINUOUS DRAW (L) ³	-	-	610	848	-	-	786	1097	-	-	1037	1435
	POWER (kW)	-	-	35	49	-	-	46	64	-	-	60,3	83,4
	PREHEATING ³ (min)	-	-	21	15	-	-	21	15	-	-	21	15
NL ⁴	5				12				19				
MODEL		WP2X 00600R				WP2X 00800_				WP2X 01000_			
	HEAT EXCHANGER (m ²) [L] ¹	5,0 [35,5]				5,2 [36,9]				6,0 [42,6]			
	PRIMARY FLOW (m ³ /h)	3				3				3			
	PRIMARY TEMP. (°C)	50	60	70	80	50	60	70	80	50	60	70	80
DHW FROM 10 TO 45 °C	LITRES 10' (L/10') ²	526	630	876	961	611	718	1000	1088	717	833	1160	1256
	LITRES FIRST HOUR ²	1352	1975	2672	3187	1462	2102	2846	3374	1666	2363	3193	3767
	CONTINUOUS DRAW (L) ³	1042	1699	2269	2812	1075	1748	2332	2888	1198	1933	2568	3173
	POWER (kW)	42	69	92	114	44	71	95	118	49	79	105	129
	PREHEATING ³ (min)	26	15	11	9	31	18	13	11	34	20	15	12
DHW FROM 10 TO 60 °C	LITRES 10' (L/10') ²	-	-	550	620	-	-	635	708	-	-	743	822
	LITRES FIRST HOUR ²	-	-	1490	1915	-	-	1604	2040	-	-	1820	2295
	CONTINUOUS DRAW (L) ³	-	-	1188	1635	-	-	1224	1683	-	-	1361	1861
	POWER (kW)	-	-	69,1	95,1	-	-	71	98	-	-	79	108
	PREHEATING ³ (min)	-	-	23	16	-	-	27	19	-	-	30	21
NL ⁴	23				29				34				
MODEL		WP2X 01500_				WP2X 02000_							
	HEAT EXCHANGER (m ²) [L] ¹	7,5 [53,2]				8,5 [60,3]							
	PRIMARY FLOW (m ³ /h)	4				4							
	PRIMARY TEMP. (°C)	50	60	70	80	50	60	70	80				
DHW FROM 10 TO 45 °C	LITRES 10' (L/10') ²	1060	1209	1690	1813	1334	1495	2092	2224				
	LITRES FIRST HOUR ²	2265	3160	4287	5025	2657	3620	4912	5703				
	CONTINUOUS DRAW (L) ³	1522	2464	3281	4058	1670	2685	3562	4395				
	POWER (kW)	62	100	134	165	68	109	145	179				
	PREHEATING ³ (min)	42	24	18	14	51	29	21	17				
DHW FROM 10 TO 60 °C	LITRES 10' (L/10') ²	-	-	1093	1195	-	-	1370	1479				
	LITRES FIRST HOUR ²	-	-	2464	3074	-	-	2871	3527				
	CONTINUOUS DRAW (L) ³	-	-	1731	2373	-	-	1896	2587				
	POWER (kW)	-	-	100,7	138,0	-	-	110,3	150,4				
	PREHEATING ³ (min)	-	-	36	25	-	-	44	31				
NL ⁴	59				78								

(1) Volume of fluid contained in the heat exchanger

(2) Obtainable with pre-heated cylinder (at 45 °C with primary side set at 50 or 60 °C and pre-heated at 60 °C in the other cases) and a running heat source

(3) With a proper power heat source generator

(4) Primary side 80 °C - Secondary side 10-45 °C

WP2X - Upper heat exchanger powers with secondary side at 10/45 °C

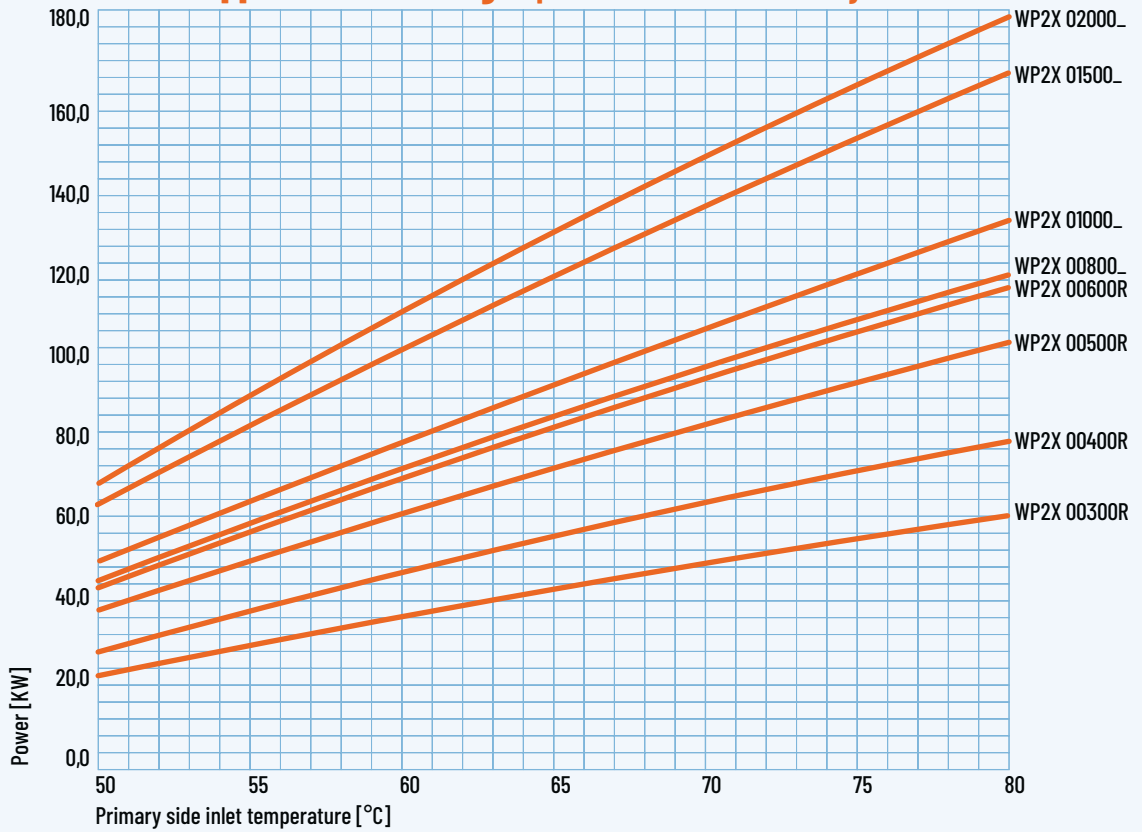

WP2X - Upper heat exchanger pressure drops

